

TOP VIEW

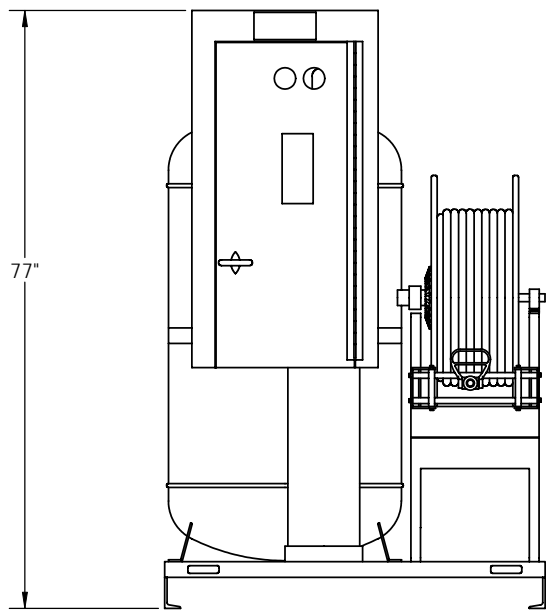

FRONT VIEW

BURNER FIRE CONTROL

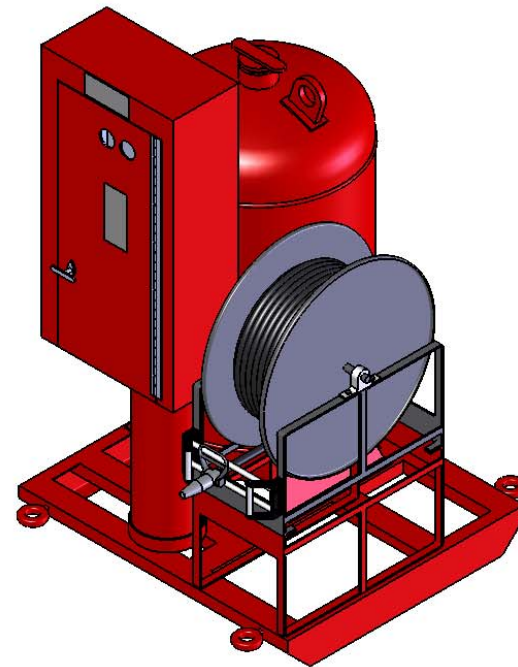

ISOMETRIC VIEW

150 GALLON AFFF UNIT

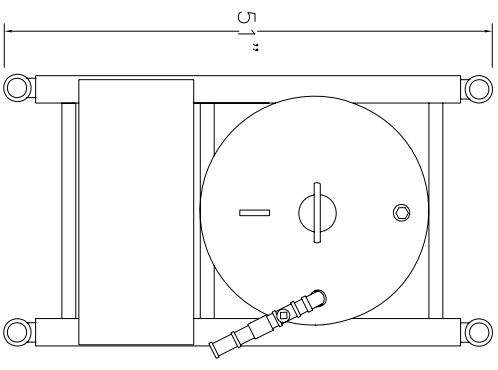
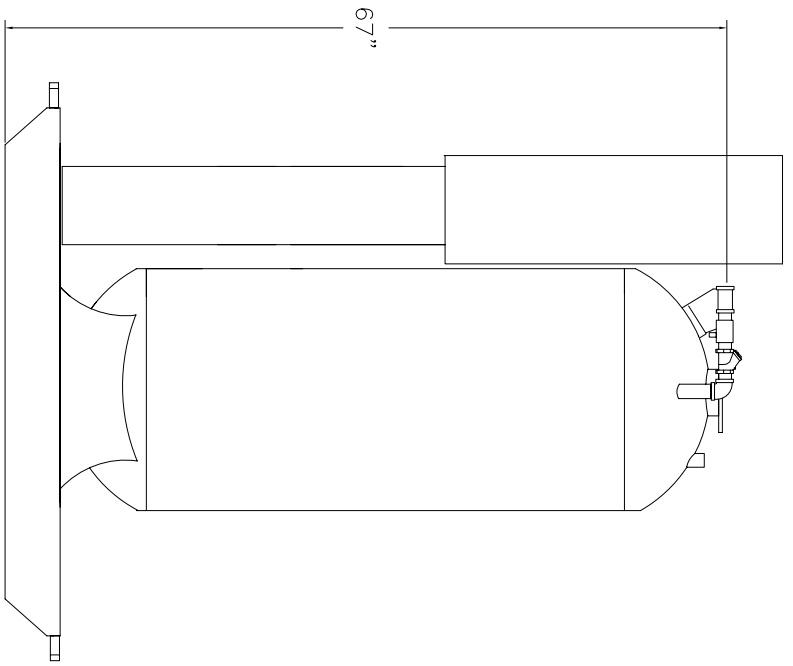
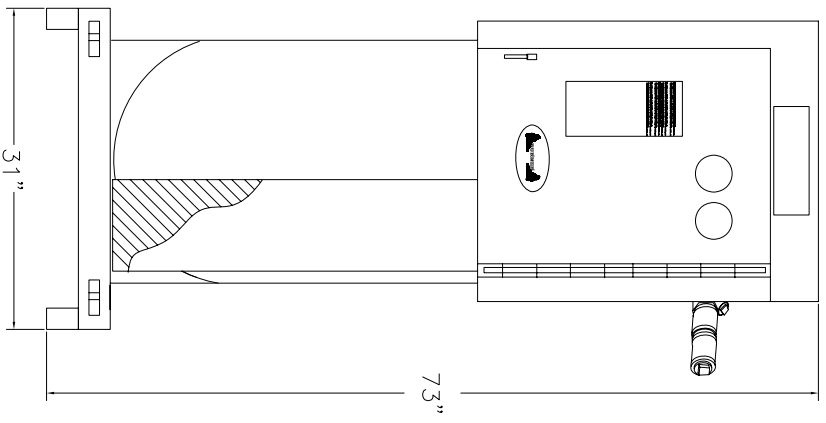

SPECIFICATIONS-150 GALLON AFFF UNIT	
300 CU. FT. NITROGEN CYLINDER	1
DECK CLEARANCE (INCHES)	4
SAFETY POP-OFF (PSI)	250
FILLER CAP(I. D. INCHES)	4
VICTOR 700-E REGULATOR	1
NITROGEN CYLINDER PRESSURE GAUGE	1
ELKHART VALVES	1
BRASS AIRIATION FOAM TIP	1
REMOTE PNEUMATIC ACTUATORS	1
NITROGEN CYLINDER BACK CHECK	1
HOSE PURGE BACK CHECK	1
A.S.M.E. CODE EXTINGUISHER CYLINDER	YES
COMPONENTS U.L. LISTED	YES
PERCENTAGE AFFF PRE-MIX	6%
AFFF SHIPPED WITH UNIT GALLONS	9
INSPECTION PORTS IN CABINET	YES
LOW PRESSURE MANIFOLD	1
REMOTE CONTROL CONNECTIONS	2

NOTES:
 DRY WEIGHT OF UNIT-----1,085 LBS.
 FULL WEIGHT OF UNIT-----2,420 LBS.



We support and encourage NICET certification

THIS DRAWING IS CAD GENERATED AND THE PROPERTY OF BURNER FIRE CONTROL, INC.
 USE OR REPRODUCTION OF ANY PORTION MUST BE WITH THE CONSENT OF BURNER FIRE CONTROL, INC.



DRAWN BY: D. DELGAMBE DATE: 4/12/07
 APPROVED BY: _____ DATE: _____

COMPANY: AMERICAN FIRE EQUIPMENT
 FACILITY: _____
 DRAWING: 150 GALLON AFFF UNIT
 DRAWING #: AF-150-1