

American Fire Equipment

Product Specification

21 GALLON STORED ENERGY CAFS (Horizontal) Compressed Air Foam System

Performance

Pressure Vessel Capacity	21 Gallons
CAFS output.....	1" outlet - 12 GPM of Solution 210 Gallons finished foam
Discharge Range.....	55 Feet Sustained

General Specifications - Standard

Pressure Vessel Type.....	2:1 ASME Code Head – Elliptical
Pressure Vessel Construction Standards.....	Built to ASME Code by ASME Coded Facility
Pressure Vessel Construction.....	Carbon Steel
Pressure Vessel Diameter.....	24"
Pressure Vessel Lining.....	Vessel Lined With an Interior Protective Coating
Fill Diameter.....	2 ½" Diameter
Draw Tube.....	Special Design for Interior CAFS Mixing
System Hoses.....	Braided Stainless Steel
Plumbing.....	All Brass Fittings
Discharge Hose.....	1"x 50' Forestry Hose with Extruded Alum. Couplings
Hose Storage.....	Aluminum Hose Tray
Expellant Type.....	Nitrogen, Breathing Air or Shop Air
Expellant Cylinder Capacity.....	40 Cubic Feet
Bottle Bracket.....	SCBA Clip Type, Back Plate and Retainer Strap
Regulator.....	Victor SR-250
Discharge Nozzle.....	1" Chrome Plated with Shutoff
Discharge Tip.....	Aluminum Straight Bore
Foam Compatibility	Class A - B - D
Frame Construction.....	Welded Aluminum
Finish.....	Powder Coated

Dimensions

Depth	24 inches
Width	32 inches
Height	20 inches
Weight Empty	100 lbs
Weight Full	282 lbs

Support Requirements

- ✓ Foam concentrate – 12 to 36 ounces
- ✓ Spare Air Cylinder (Recommended)

Optional Features

- ✓ Hose reel with 50 or 100 feet 1" booster hose
- ✓ 100 foot lay flat hose



Contact Information

American Fire Equipment (A Division of Burner Fire Control, Inc.)
301 Industrial Pkwy Lafayette, LA 70508

Web: www.burnerfire.com E-mail: kscott@burnerfire.com PH: (337) 237-4547

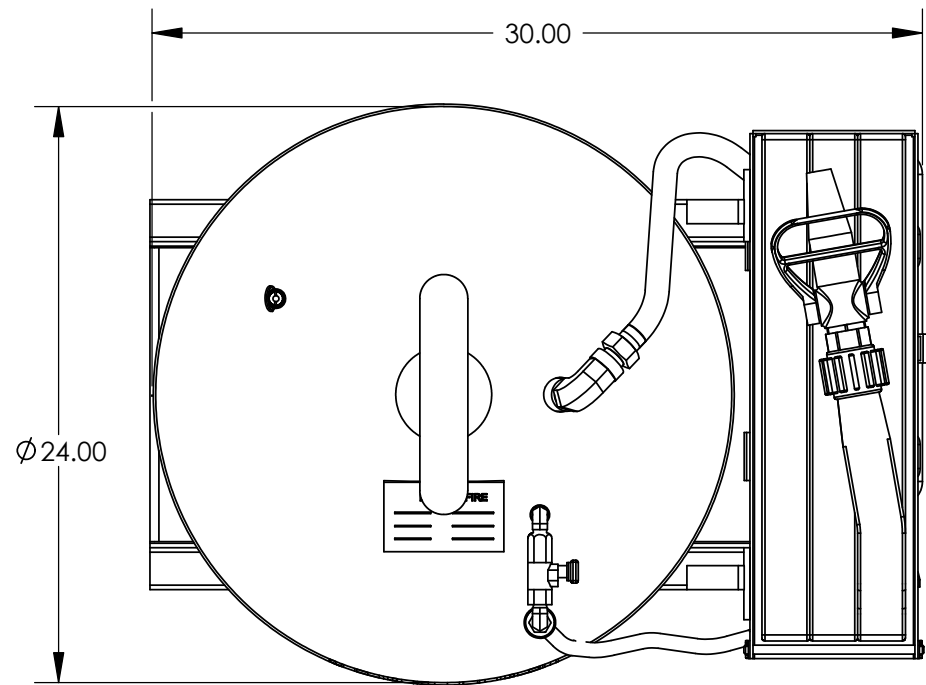

TOP VIEW

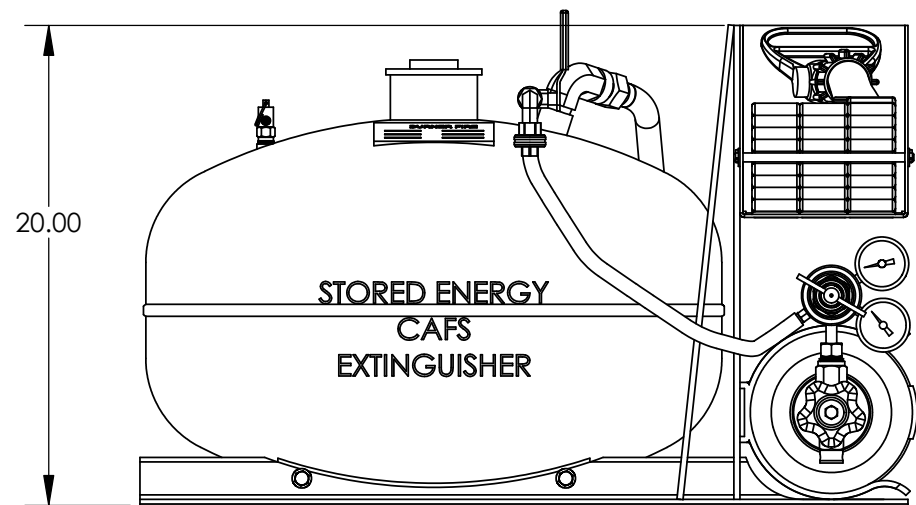

FRONT VIEW

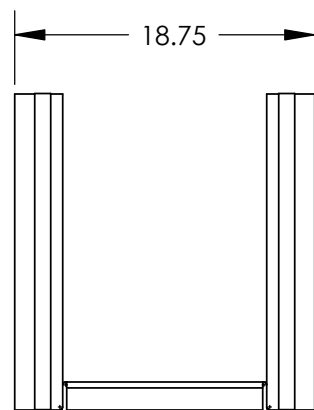

END VIEW OF SKID

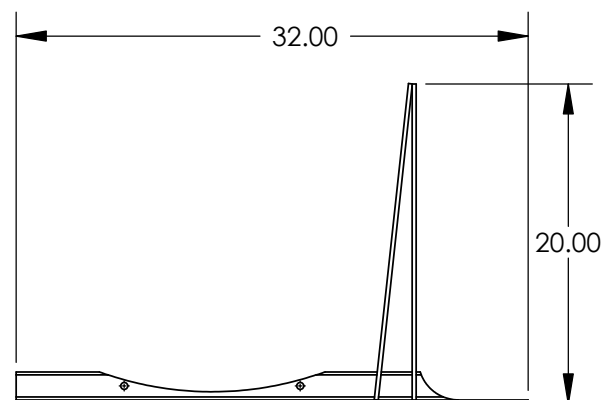

FRONT VIEW OF SKID

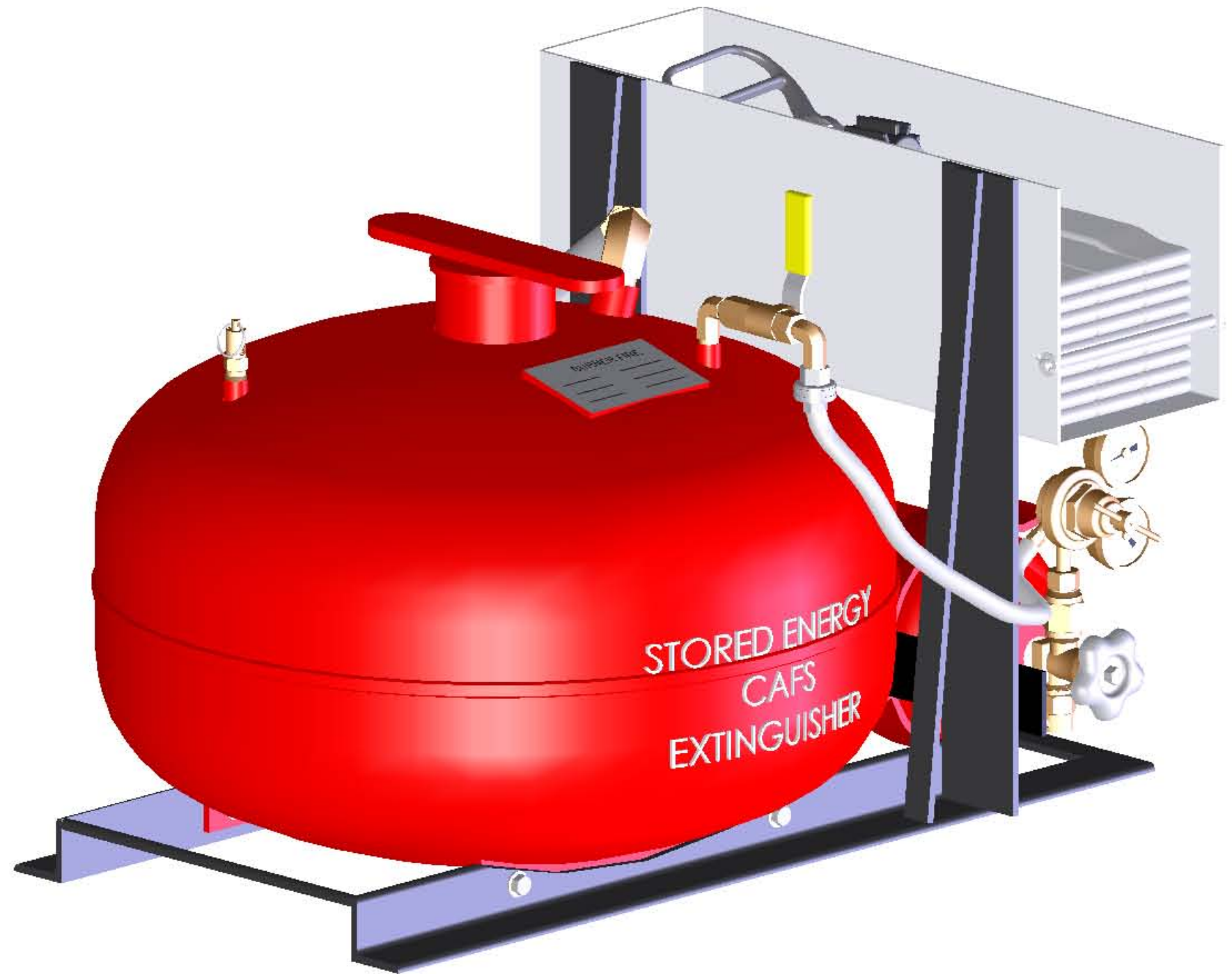

21 GALLON HORIZONTAL COMPRESSED AIR FOAM TANK